



DATA SHEET STEAM TRAP THERMODYNAMIC PT-55 | PT-60



PT KLINGER is a thermodynamic steam trap designed with cycle control that makes the disc work evenly and block the passage of steam in its entire area. Robust and highly resistant to water hammer, the PT is ideal for draining condensate in saturated steam distribution lines up to 42 bar.

OPERATION CONDITIONS:

- » Maximum operating pressure: 42 bar @ 252°C;
- » Minimum operating pressure: 0.25 bar(g);
- » Maximum back pressure: 80% of the operating pressure;
- » Maximum temperature: 450°C.

DIAMETERS AND CONNECTIONS:

- » 1/2", 3/4" and 1";
- » BSPT and NPT thread;
- » BW and SW welding with extensions and union nut;
- » Class 150#, 300# or 600# adapted flanges.

ACCESSORIES:

- » Built-in filter.



MEASURES:

DN	A- NPT	A- 150	A- 600	A- SW	B	C	D	E	WEIGHT (KG)
1/2"	48	124	144	168	48	57	70	40	0,63
3/4"	56	132	152	192	56	63	77	43,5	0,92
1'	66	136	156	220	66	77,5	91	54	1,5

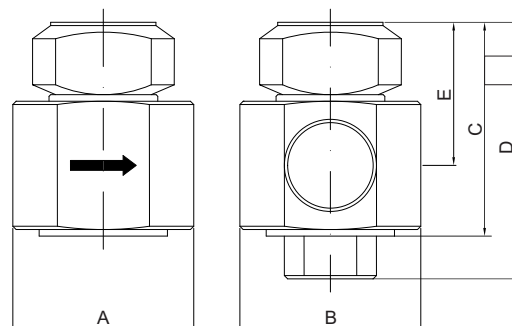

FLOW CAPACITY

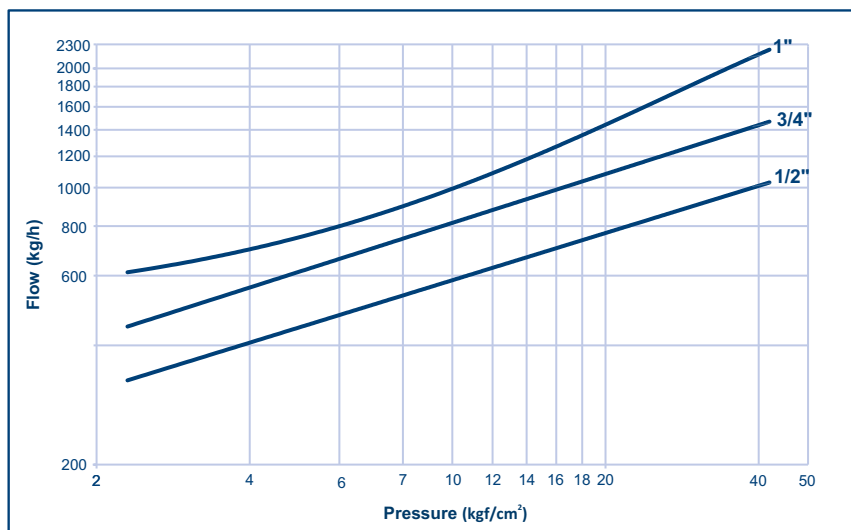



DATA SHEET STEAM TRAP THERMODYNAMIC PT-55 | PT-60



MATERIAL:

ITEM	DESCRIÇÃO	MATERIAL
1	Cap	Stainless steel AISI 420
2	Disc	Stainless steel AISI 420
3	Body	Stainless steel AISI 420 with hardened seat
4	Strainer	Stainless steel AISI 304 05 mm
5	Washer	Stainless steel AISI 304
6	Stopper	Stainless steel AISI 420

